罐阀 2.0 技术
 2.0 TECHNOLOGY FOR TANK VALVE

升级版2.0: 提升阀杆优化与三爪的配合, 不易卡住; 花篮根部增加了大的导向斜度, 阀杆轻易能够弹回准确的密封位置; 花篮整体成型, 工艺变形大大小于原来的三爪; 流道设计更顺滑, 相同条件下流量增加了10%。

Update 2.0: Poppet and the hooks matches better, seldom jams; With the guidance of the draft angle at the bottom of the gasket, the poppet can reach the sealing position accurately; Less distortion of the basket than 3 hooks; A smoother flow route increases the flow rate by 10%.

高提升底阀

HIGH LIFT VALVE

基本配置 Basic Details

3" 45° 提升式脚阀 — 入口为 8 x Φ 14mm, 178mm PCD 法兰等分通孔; 出口法兰有 4 x Φ 17mm, 160mm PCD 法兰等分螺孔。接触货物的零件采用 316 不锈钢制造, 阀板配备标准的夹层密封圈。另有可选项: 30°、90° 和 180° 提升式脚阀; 蒸汽加热。我们也提供 4-8" 的产品。同时提供耐腐蚀性更优越的哈氏合金阀。

3" 45° MKIII Highlift Footvalve

Options: inlet flange drilled 8 x 14mm holes equi-spaced on a 178mm PCD; outlet flange drilled 4 x 17mm holes on a 160mm PCD. Contact parts manufactured in 316 stainless steel with combined main seal as standard. Other poppet seal materials available. Footvalve may be manufactured in other metals. Full range of 30°, 90° and 180° highlift footvalves. Steam heated option. Available with integral Hastelloy seat area. A range of bolt kits and outlet gaskets are available. We also make 4-8" footvalves.

规格 Specification

重量	Weight	8.9 KG
设计压力	Design Pressure (MAWP)	4 Bar (58 PSI)
测试压力	Test Pressure	6 Bar (87 PSI)
设计温度	Design Temperature	-40°C to 200°C (-55°F to 392°F)

FITTING DIMENSION

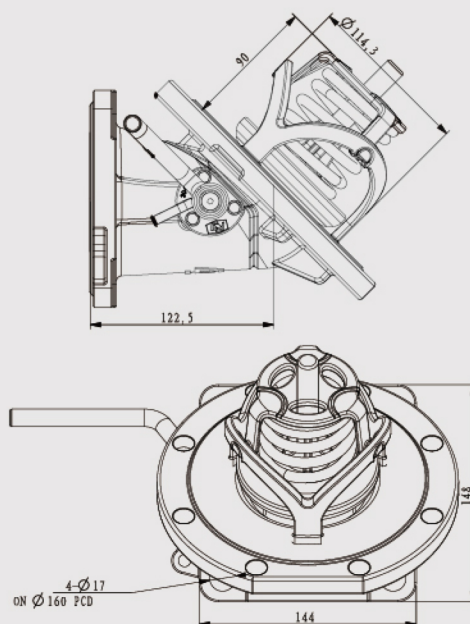

Example shown : 826-1200A

1 标准配置 Basic configuration

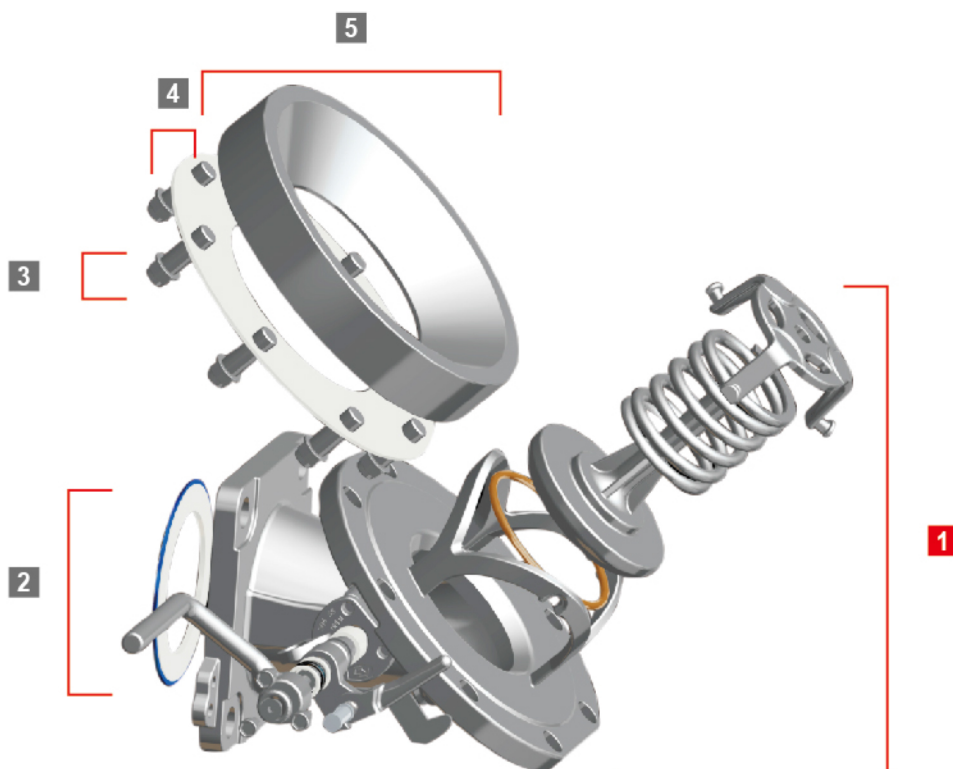

为了确保罐体在出现事故时保持密封，我们在阀体上增加了一个剪力槽；这样，当阀门受损时将在剪槽处断裂，而阀板及法兰仍然附着于罐体并保持密封。

To ensure that the tank remains sealed in the event of an accident, the valve body incorporates a shear groove, designed to fail in such a way as to leave the internal part of the valve closed and attached to the tank body. To ensure that the tank remains sealed in the event of an accident, the valve body incorporates a shear groove, designed to fail in such a way as to leave the internal part of the valve closed and attached to the tank body.

选装部件

OPTIONAL COMPONENTS

罐阀 2.0 技术

2.0 TECHNOLOGY FOR TANK VALVE

2 出口标准垫片CNAF/PTFE复合垫片5005-049;	2 Gasket for outlet;
3 罐体法兰连接螺栓包324-2070;	3 Bolt kit for flange;
4 8孔CNAF/PTFE复合垫片5005-015;	4 Gasket for inlet;
5 常用罐体8孔法兰324-9000	5 Welding flange for tank

防尘盖

DUST CAPS

除以下列出的防尘盖外我们也提供一系列不锈钢检查盖，操作人员可通过其观察是否存在压力。

A range of stainless steel check caps is also available. These comprise a cap with an indicator which allows the operator to check if there is any residual pressure. The part numbers have a 'CK' suffix instead of the 'PS'.



BSP 不锈钢

BSP - Stainless Steel

说明 Description	零件号 Part No.
1/2" BSP不锈钢盖, 带线和PTFE垫圈	10316PS
3/4" BSP不锈钢盖, 带链和PTFE垫圈	10306PS
1" BSP不锈钢盖, 带链和PTFE垫圈	10305PS
1 1/2" BSP不锈钢盖, 带链和PTFE垫圈	10300PS
2" BSP不锈钢盖, 带链和PTFE垫圈	10301PS
2 1/2" BSP不锈钢盖, 带线和PTFE垫圈	10302PS
3" BSP不锈钢盖, 带链和PTFE垫圈	10303PS
4" BSP不锈钢盖, 带线和PTFE垫圈	10304PSC

BSP - 铝

BSP - Aluminium

说明 Description	零件号 Part No.
3/4" BSP铝盖, 带链和皮垫圈	10706AL
1" BSP铝盖, 带链和皮垫圈	10707AL
1 1/2" BSP铝盖, 带链和皮垫圈	10708AL
2" BSP铝盖, 带链和皮垫圈	10709AL
2 1/2" BSP铝盖, 带链和皮垫圈	10710AL
3" BSP铝盖, 带链和皮垫圈	10711AL

NPT

说明 Description	零件号 Part No.
1 1/2" NPT不锈钢盖, 带链和Teflon垫圈	10300NPTP
2" NPT不锈钢盖, 带链和Teflon垫圈	10301NPTP
3" NPT不锈钢盖, 带链和Teflon垫圈	425-3240
3" NPT铝盖, 带黄铜链和皮垫圈	10711NPT

垫圈

Washers

说明 Description	零件号 皮质 Part No. LEATHER	零件号 PTFE Part No. PTFE
1/2" 垫圈	1/2" washer	-
3/4" 垫圈	3/4" washer	10331L
1" 垫圈	1" washer	10319L
1 1/2" 垫圈	1 1/2" washer	10326L
2" 垫圈	2" washer	10327L
2 1/2" 垫圈	2 1/2" washer	10328L
3" 垫圈	3" washer	10329L

如果以上内容未列出您需要的尺寸或材料, 请联系我们的销售团队。

Please contact our Sales team if the size or material you require is not listed here.



保险盒

FUSE LINK

保险盒在发生火灾时会实现脚阀（主阀门）自动切断。本设备包含设计温度为 100°C (212°F) 的易熔断片，其连接到遥控切断拉绳上。能便捷的安装到集装罐框架上，适用于所有集装罐及不同种类的脚阀。符合 U.S.DOT CFR49–ch.178275[d]

Fuse link effects the automatic closure of the footvalve (primary valve) in case of fire. The device incorporates a fusible element designed to operate at 100°C (212°F) and is linked to the remote closure cable. Quick and easy to fit on the container tank frame and compatible with all tank designs and with most footvalves on the market. Complies with U.S. DOT CFR49 – ch.178275 [d].

规格 Specification

重量	Weight	0.5 KG
设计温度	Operating Temperature	100°C (212°F)

相关零件

Associated Parts

零件号 Part No.	说明	Description
6110-022	25mm 7X7线-6.5米长	2.5mm 7x7 strand st/st wire – 6.5 metre length
324-5341	线夹	Wire clamp
5104-203	遥控切断装置张力弹簧	Remote closure tension spring
324-7610	脚阀手柄遥控操纵杆	Footvalve handle remote operating lever

零件图

Parts drawing

零件号 Part NO. : 324-5760

序号 Item	说明	Description	零件号 Part No.
1	不锈钢链（9节链）	Stainless steel chain (9 links)	6128-016
2	100°C熔断片	100°C fusible element	324-5616
3	张力弹簧	Tension spring	252-3272
4	遥控切断装置支架	Remote closure bracket	324-5765
5	不锈钢环	Solid ring	613-6150
6	线夹（每组2只）	Wire clamp (2 per assembly)	324-5341

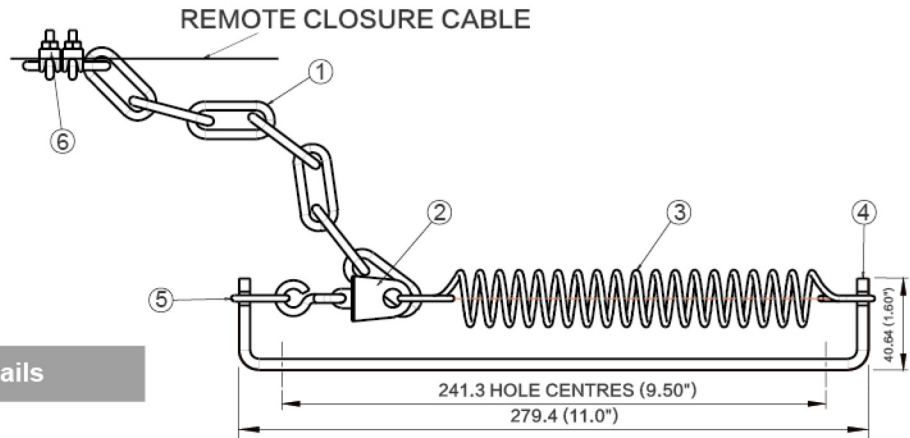

设置明细

Setting details

1. 将支架用MG螺钉固定在集装罐框架上。
2. 使用线夹将遥控切断拉绳固定到链条上，确保当阀处于打开位置时，链条的松弛度最低。

1. Drill & tap tank frame m6 at centres quoted clamp remote closure wire to chain using cable connectors.
2. Ensure that there is minimum amount of slack on the chain when the valve is in the open position.